



# Massachusetts Bay Transportation Authority

MBTA Contract No. A90PS01:  
Engineering and Design Services for the MBTA  
Downtown Crossing Station Accessibility Improvements Project, Phase II

---

Fiscal and Management Control Board

John McCormack

March 23, 2020

# Project History



Street View of Downtown Crossing Station Area

- All of the stations on both the Red and Orange Lines are accessible.
- The lack of an accessible connection between the two lines is a significant barrier to our customers.
- The current paths are so confusing that even with improved wayfinding, lighting and staff assistance, making the connection is a daunting task for everyday customers, and a nearly impossible one for the less experienced.
- The completed DTX Phase One Accessibility Improvements project made an accessible transfer between the Red Line Northbound and the Orange Line Northbound.



# Project Scope

The Downtown Crossing Phase II Project Scope includes three new elevators:

- **Summer Street Concourse (Macy's Elevator):** New elevator between Orange Line Northbound and Red Line Southbound
- **Winter Street Concourse at Park Street (Elevator 808):** An enlarged and relocated new Elevator 808 that connects Red Line Northbound and Orange Line Southbound at Downtown Crossing via Winter Street Concourse
- **Washington Street Elevator (Winter Street Building):** New replacement elevator that connects Washington Street, Orange Line Southbound, and Red Line Southbound



Existing



Proposed

Summer Street Concourse (Macy's Elevator) Concept

# Project Scope

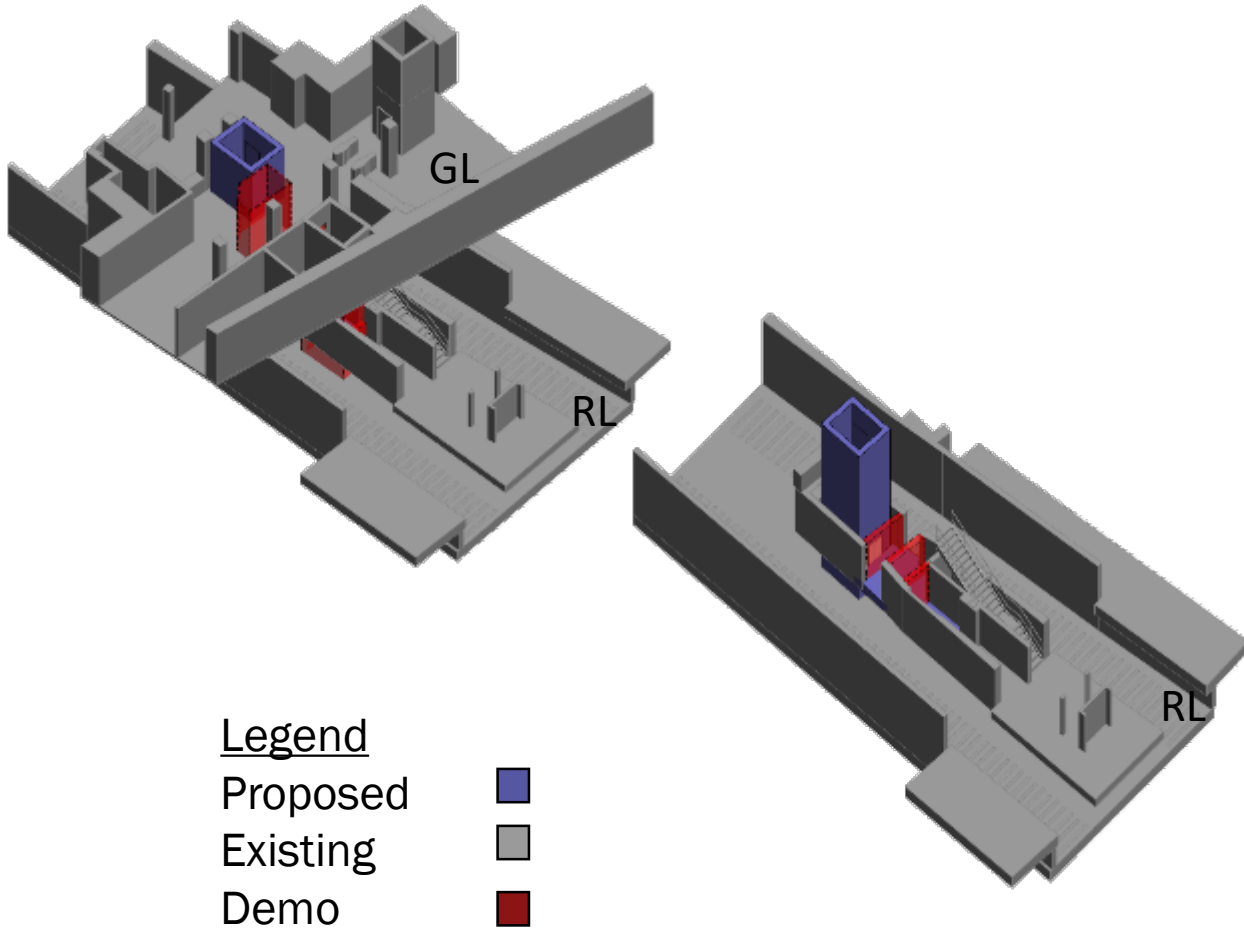

Winter Street Concourse at Park Street (Elevator 808)

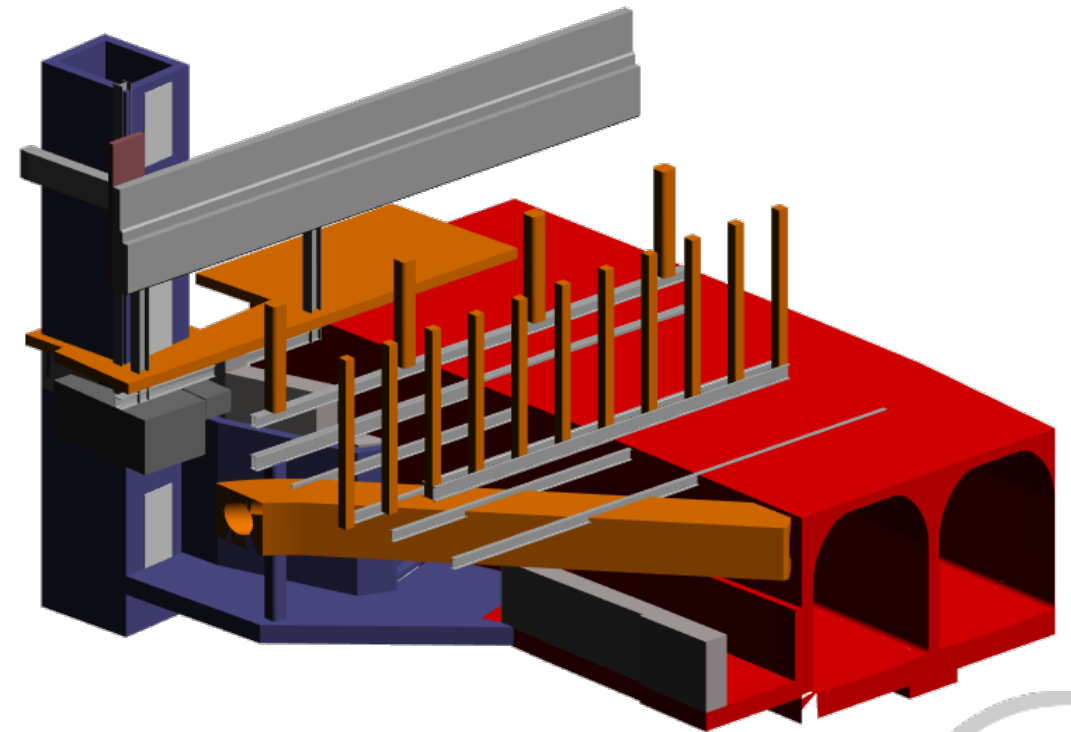

Washington Street Elevator (Winter Street Building)



# Project Scope

The services will be delivered on a Task Order basis by Phase. Project Phases for this project are defined to be:

- Phase II Preliminary Design (15% - 30%)
- Phase III 75% Design (30% - 75%)
- Phase IV Final Design (75% - PSE)
- Phase V Bid Phase
- Phase VI Construction Phase Services

- The contract duration is expected to be April 2020 – April 2024.
- Design and Bid Phase Services are expected to be complete within two years.
- Construction Phase Services are expected to be complete two years from NTP for construction.



# Project Benefits

- Improve customer experience, safety, and accessibility
- Provide accessible transfers between Orange Line and Red Line and equitable access to all customers
- Implement ADA upgrades to fulfill code compliance requirements and important FTA obligations
- Comply with BCIL accessibility improvements agreement
- Reduce lifecycle maintenance costs

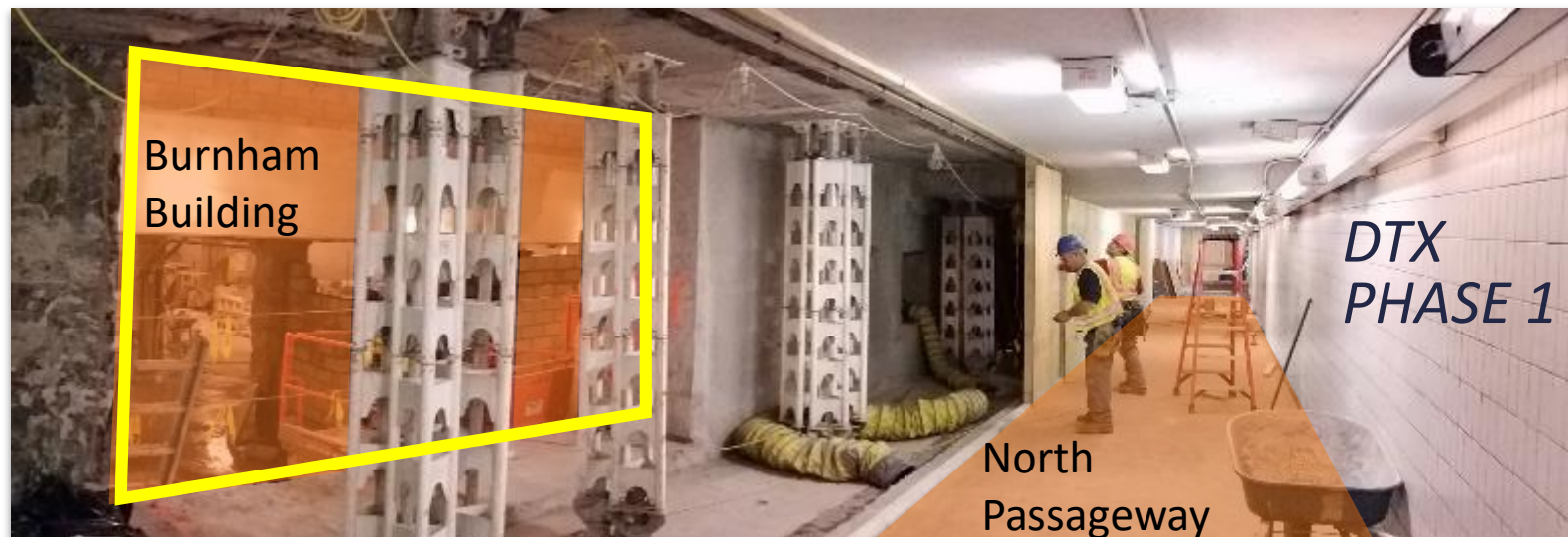

# Request of the Fiscal and Management Control Board

---

Today's board action will provide for Design Phase, Bid Phase and Construction Phase Services for the Downtown Crossing Station Accessibility Improvements Project, Phase II. The total project budget is \$50,000,000, and the design phase represents 14% of the total budget.

Staff request that the Fiscal and Management Control Board authorize the MBTA General Manager, or his designee, to award and execute **MBTA Contract No. A90PS01**: Engineering and Design Services for the MBTA Downtown Crossing Accessibility Improvements Project, Phase II with **Mott MacDonald, LLC** for an amount not to exceed **\$6,879,849**.



# Appendix





# Project Purpose

---

- The design and eventual construction of these three new elevators will yield accessible connections between the Red and Orange Lines resolving the current barriers that have plagued customers since the station's construction in 1910 and will be a meaningful milestone towards the MBTA's plan to become 100% accessible.
- Simple equitable transfers available between the Red Line Southbound and Orange Line North and Southbound.
- Simple accessible transfer between the Red Line Northbound and Orange Line Southbound via the Red Line's Park Street Station and the newly renovated Winter Street Concourse.
- To build upon the completed DTX Phase One Accessibility Improvements project which provides accessible transfers between the Red Line Northbound and the Orange Line Northbound
- Fulfill important FTA obligations as well as one of the final commitments in the MBTA's settlement agreement with the Boston Center for Independent Living (BCIL) that was signed in 2006.



# Public Engagement and Outreach

---

Stakeholder Engagement and Public Participation Plan includes:

- Providing a Municipal Liaison throughout the duration of the project to coordinate with stakeholders, abutters, City of Boston, local utilities, Business Improvement District, and others, as required
- Coordinating with abutters at Macy's and Winter Street Buildings
- Preparing Stakeholder Briefings, fact sheets, and meeting materials
- Holding Public Meetings
- Attending community/neighborhood group meetings
- Monitoring and updating the project database, website, issue tracking, email updates, and responding to questions /comments /concerns

